



the **Patriot Plus**

MHD Heavy Duty

Z Series

LOADMASTER

WZ4062PU

Heavy Duty Material Handling Wheel

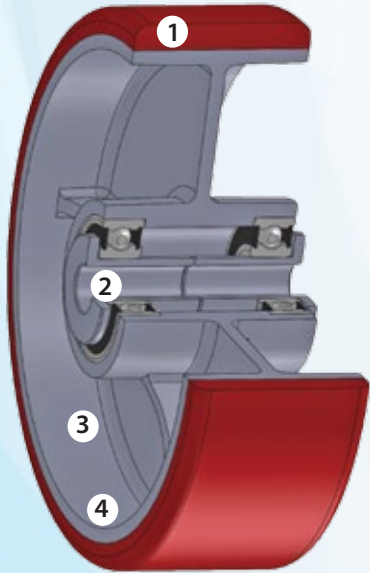

- 1 - Diecast polyurethane tread
- 2 - Top hat spanners with dual precision bearing
- 3 - Heavy duty cast steel hub
- 4 - High quality bond to hub

The P&H **LOADMASTER Z-Series** is a part of our medium duty material handling line. Featuring high quality PolyU® diecast polyurethane tread over a cast steel hub, these wheels provide superior impact resistance and effortless rolling in rugged, industrial environments.

Their quiet operation under even the heaviest loads make them ideal for industrial and institutional applications. The Loadmaster wheels are available in a wide selection of sizes and can be assembled with a variety of casters in both rigid and swivel models.

FEATURES

Wheel

- Available in diameters from 4" up to 8"
- Maintenance free design
- Supreme bond between hub and tread
- Dual layer painted hub to prevent rusting

Yoke

- Available in swivel, rigid and brake options
- NSF approved
- Zinc plated and stainless steel options
- Upper and lower raceway seals standard

Bearing

- Dual Precision Bearings with spanners
- to 1/2" bore
- Extremely quiet operation
- Handle excessive loads



Z40P382PUL*

OPTIONS

| Part No. | Diameter | Bearing | Tread Width | Load Capacity | Color/Material |
|----------|----------|----------------|-------------|---------------|----------------|
| WZ4042PU | 4" | Dual Precision | 2" | 800 lbs. | Red/Silver TPU |
| WZ4052PU | 5" | Dual Precision | 2" | 1000 lbs. | Red/Silver TPU |
| WZ4062PU | 6" | Dual Precision | 2" | 1200 lbs. | Red/Silver TPU |
| WZ4082PU | 8" | Dual Precision | 2" | 1400 lbs. | Red/Silver TPU |

WHEEL

WZ4062PU

| | |
|-----------------------|------------------|
| Diameter | 6" |
| Tread Width | 2" |
| Hub Width | 2 3/16" |
| Load Capacity | 1200 lbs. |
| Weight | 4.0 lbs. |
| Hardness (durometer) | A95 |
| Bearing | Dual Precision |
| Bore | 1/2" |
| Operating Temperature | -30° F to 140° F |

APPLICATIONS

- Warehouse
- Loading dock
- Material handling
- Manufacturers
- Hand trucks
- Conveyors
- Dollies
- Distribution



Z42P342PUL

CASTER

| Swivel | Rigid |
|--------------|-------------|
| Z40P342ZPUL* | Z42P342ZPUL |
| Z40P352ZPUL* | Z42P352ZPUL |
| Z40P362ZPUL* | Z42P362ZPUL |
| Z40P382ZPUL* | Z42P382ZPUL |

*BRAKE OPTION AVAILABLE



800 354 8622
orders@phcasters.com
www.phcasters.com



The #1 supplier of shopping cart wheels in the U.S.