

# Material Handling Wheel

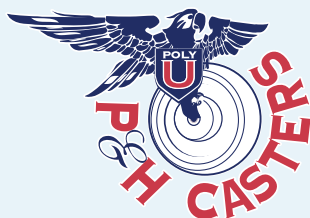

## WB2054HQ

### Series 20 Medium Duty

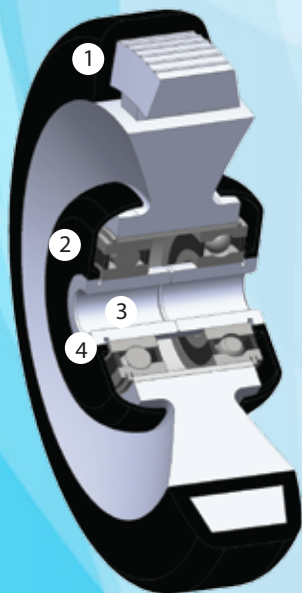

The P&H Series 20 Medium Duty material handling wheel is made from high quality thermopolyurethane, which features a softer ride in a durable wheel that is suitable for wide variety of applications.

This multi-purpose wheel also incorporates the P&H dual precision bearing system in its design, making it an exceptionally smooth, steady and quiet rolling wheel. The oversized precision bearing allows for greater load capacity than a standard shopping cart wheel.

This Series 20 material handling wheels is a versatile, general purpose product with performance that can be counted on.

- 1 - Premium Performance TPU A98
- 2 - High impact polypropylene hub
- 3 - Dual Precision Bearing system
- 4 - HDPE threadguard

## FEATURES

### Wheel

Premium performance A98 crown tread TPU  
 Exceptional maneuverability with a soft ride  
 High impact polypropylene hub  
 Long lifespan  
 Smooth, quiet operation  
 Maintenance free dual precision bearing

WH2054HQ

### Caster

A wide variety of swivel and rigid casters are available for this wheel, including premium plate casters in several different plates sizes, square, round stem and expandable stem to fit most standard carts and racks.

P&H stocks many models of casters for industrial carts and trucks, caster wheels in more than 20 materials, low-profile and shock-absorbing casters and caster brake kits.



## WHEEL

WB2054HQ

Hardness (durometer)	A98
Diameter	5"
Weight	1.0 lbs.
Tread Width	1.25"
Load Capacity	400 lbs.
Color	Black on Chrome
Hub Width	1.6"
Bore	3/8"
Wheel Bearing	Dual Precision
Temperature Range	-20° F to 130° F

## APPLICATIONS

- UBoats
- Pallet Jacks
- Dollies
- Conveyor Systems
- Ball Transfers
- Roll Carts
- Distribution
- Hospitality
- Food Service
- Backroom



800 354 8622  
[orders@phcasters.com](mailto:orders@phcasters.com)  
[www.phcasters.com](http://www.phcasters.com)



The #1 supplier of shopping cart wheels in the U.S.