

| REV NO. | Revision Note | Date | Signature | Checked |
|---------|---------------|------|-----------|---------|
| | | | | |

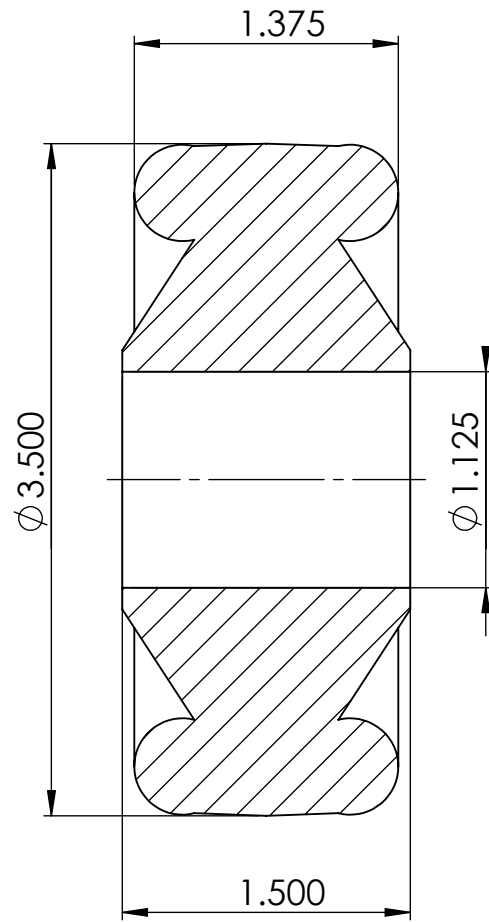
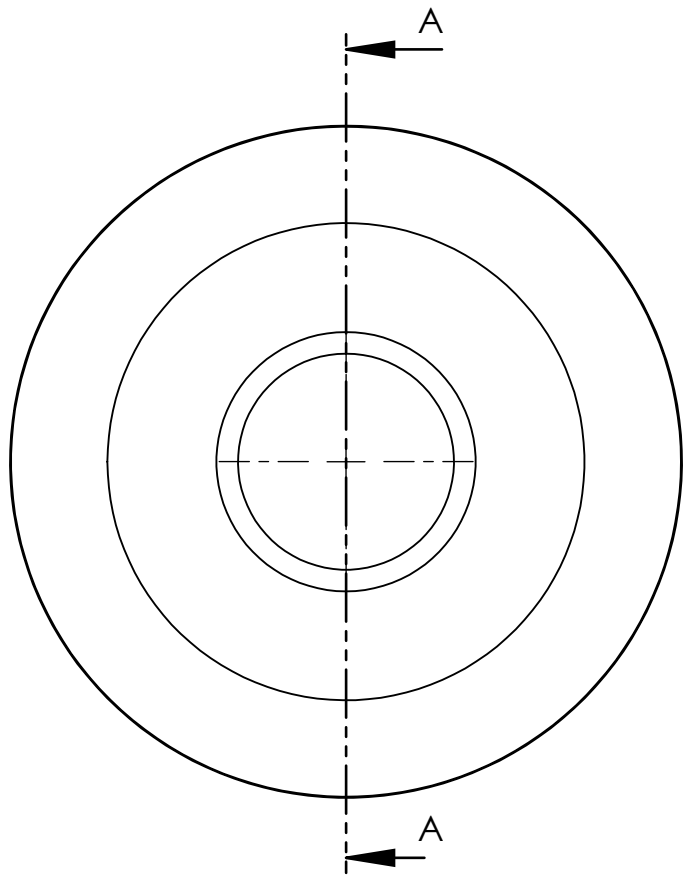
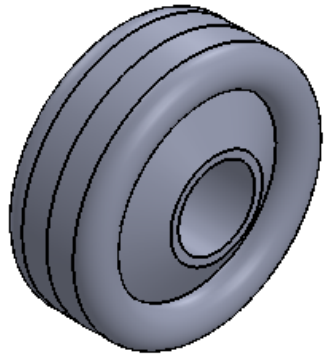

SECTION A-A
SCALE 1 : 1

| | | | | |
|--|-------------------|---------------------------|---------------------|----------------------------|
| P&H Casters | Scale 1:1 | Volume (mm ³) | Drawn By: Ashley | Date 1/24/20 |
| Description 3 1/2" x 1 3/8" White Polypropylene | | | P&H Approval | |
| Part Number 35-11M-W | Revision REV A | Sheet 01 | Date | FIRST ANGLE PROJECTION |