

REV NO.	Revision Note	Signature	Date	Checked	Date

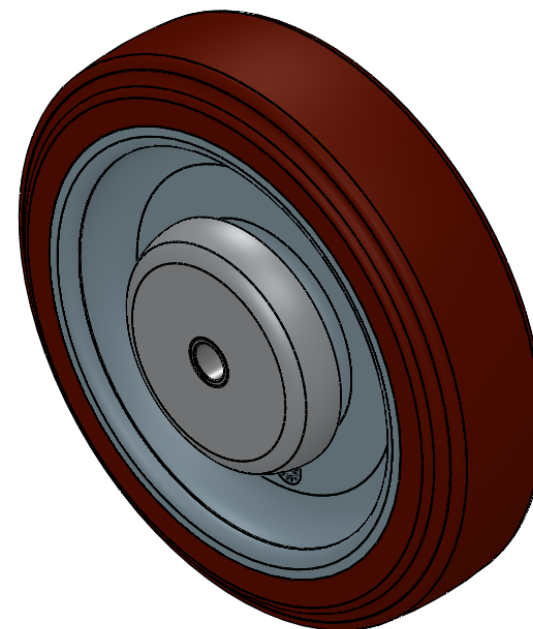
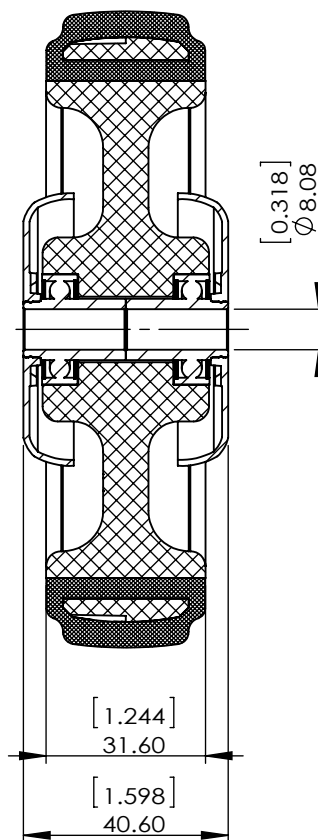
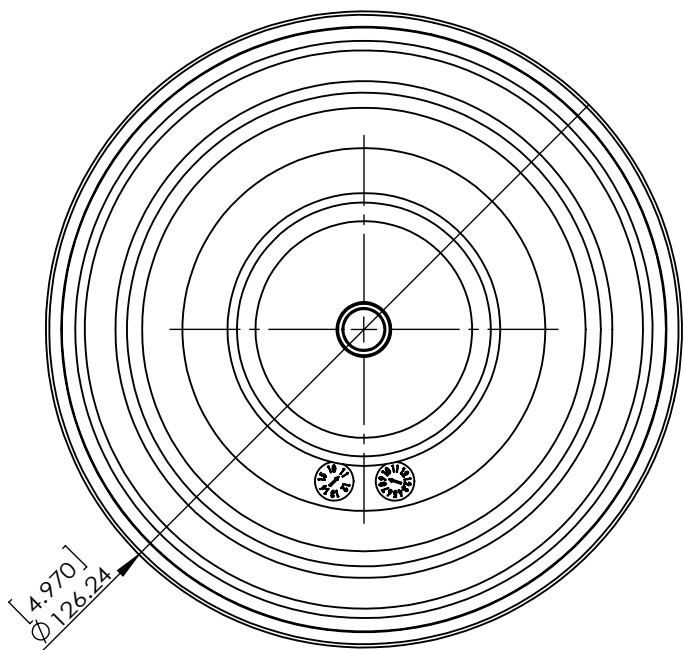

Dimensions in mm [inch]

P&H Casters		Scale	1:1.5	Volume (mm ³)	Drawn By:	Date
Description		WHEEL		Reviewed		2019/5/29
Part Number		Revision		Sheet	Date	 <small>FIRST ANGLE PROJECTION</small>
WC2054MD		REV A		01	2019/5/29	