

REV NO.	Revision Note	Signature	Date	Checked	Date

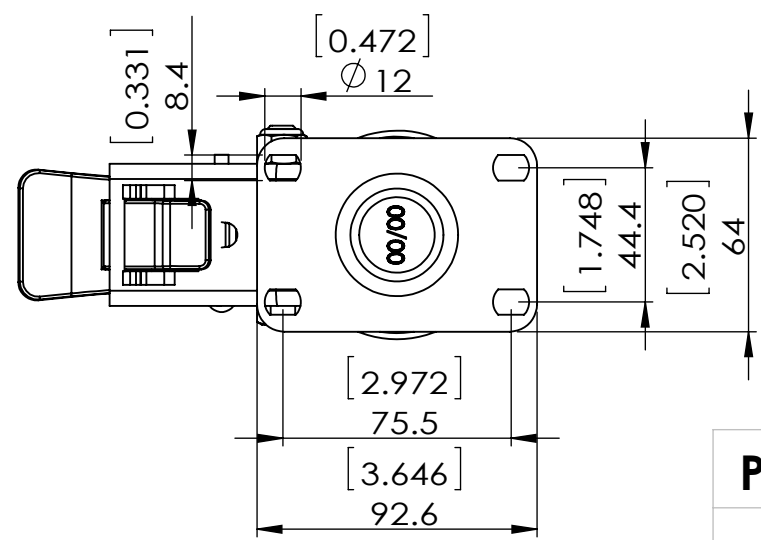
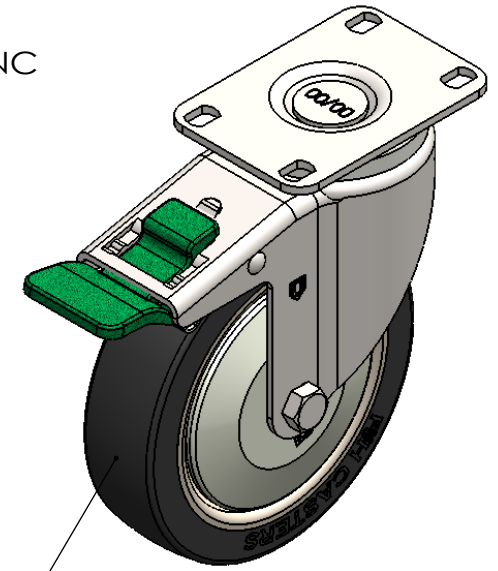
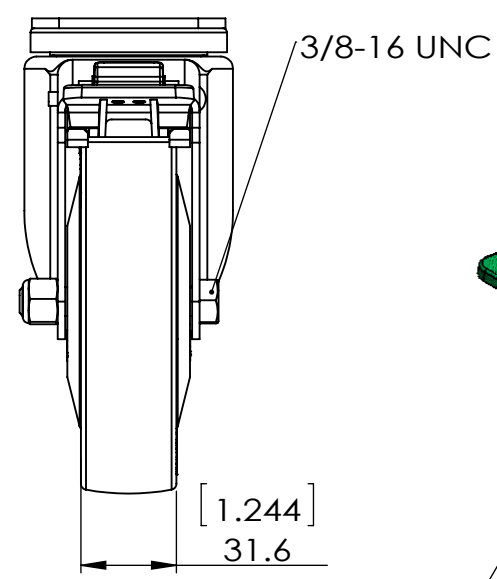
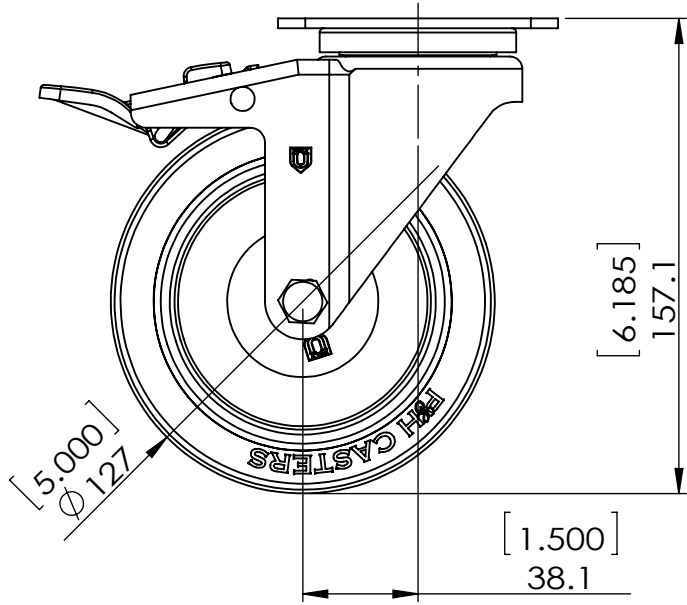
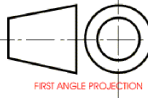

Durometer: Shore D 46 (+/-5)

Dimensions in mm [inch]

P&H Casters		Scale 1:2.5	Volume (mm ³)	Drawn By: Hua	Date 2019/4/12
Description CASTER			Reviewed Andy	 FIRST ANGLE PROJECTION	
Part Number Z26P154CTKIR REV A	Revision	Sheet 01	Date 2019/4/12		