

REV NO.	Revision Note	Signature	Date	Checked	Date

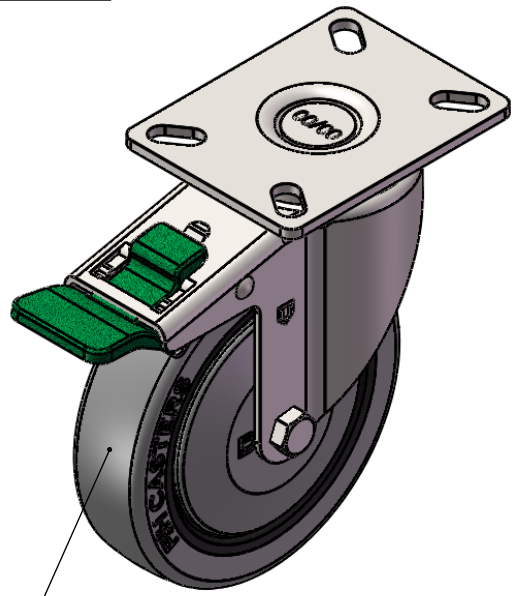

Durometer: Shore A 70 (+/-5)

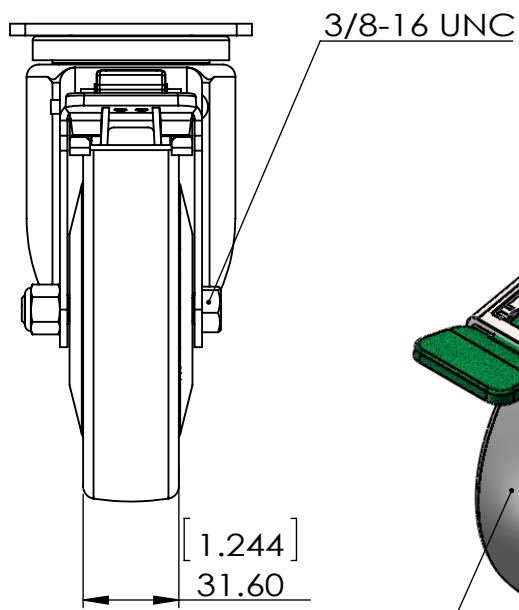
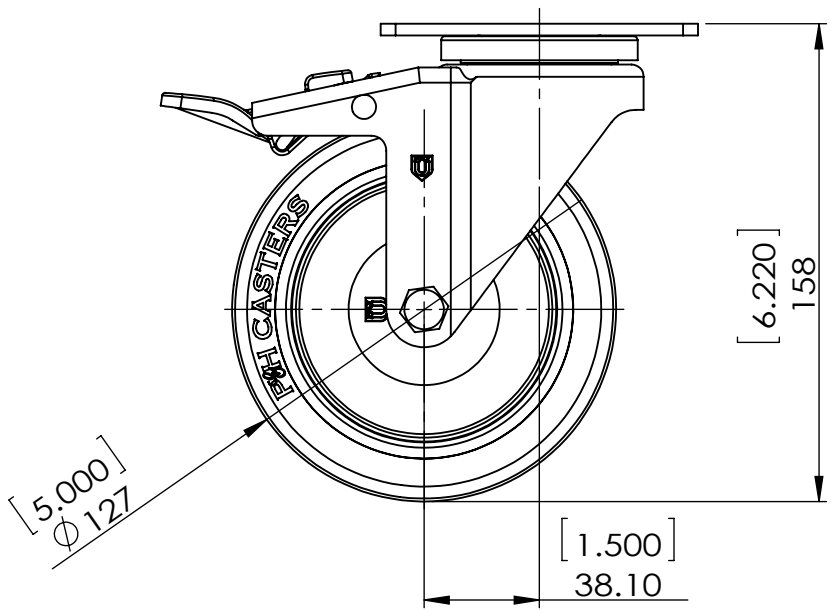
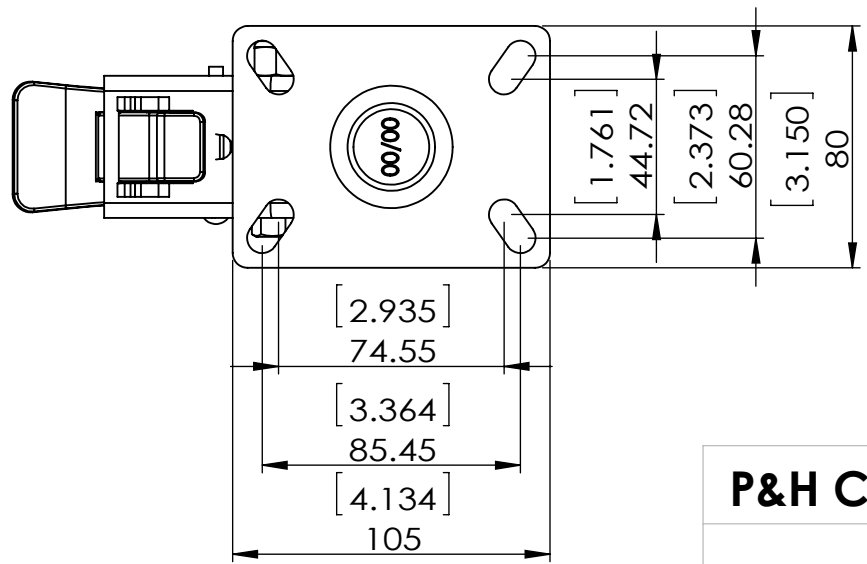

Dimensions in mm [inch]

P&H Casters		Scale	1:2.5	Volume (mm [^] 3)	Drawn By:	Date
Description		CASTER		Reviewed	Hua	2019/4/23
Part Number	Revision	Sheet	01	Date	Andy	2019/4/23
Z26P254NEKIR REV A						 FIRST ANGLE PROJECTION