

REV NO.	Revision Note	Signature	Date	Checked	Date

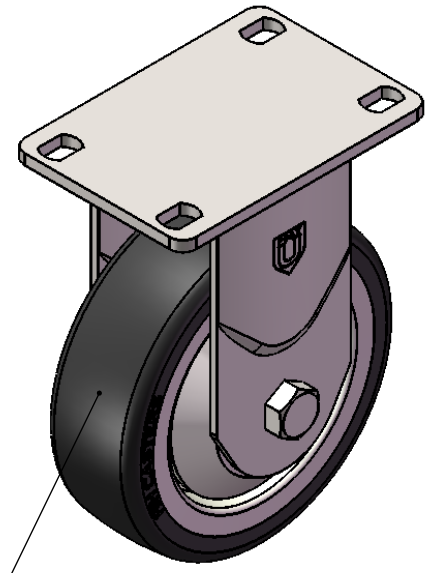

Durometer: Shore D 46 (+/-5)

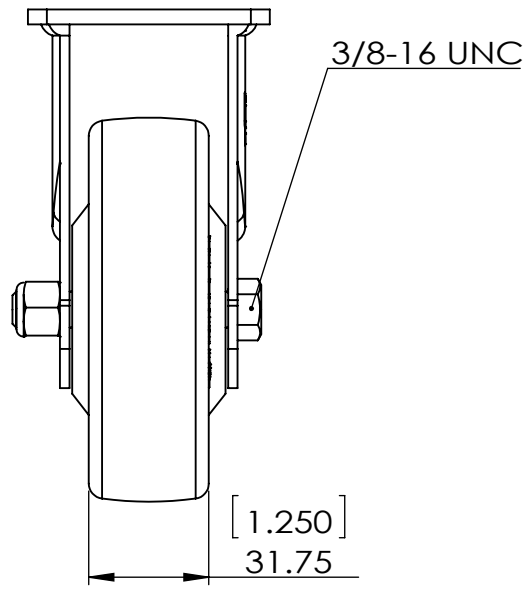
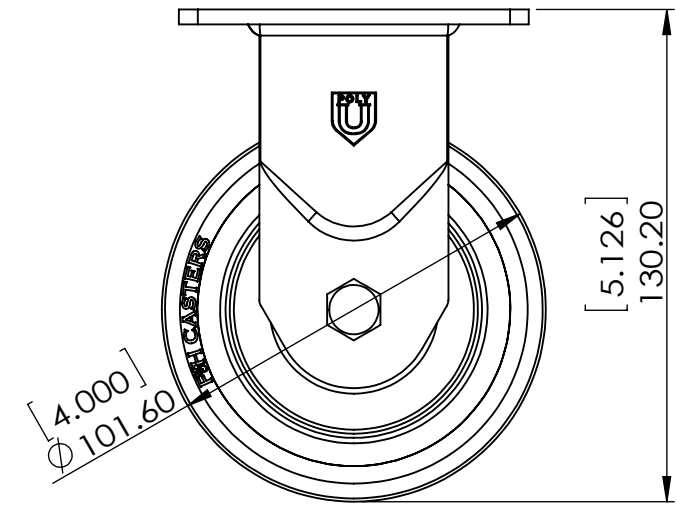
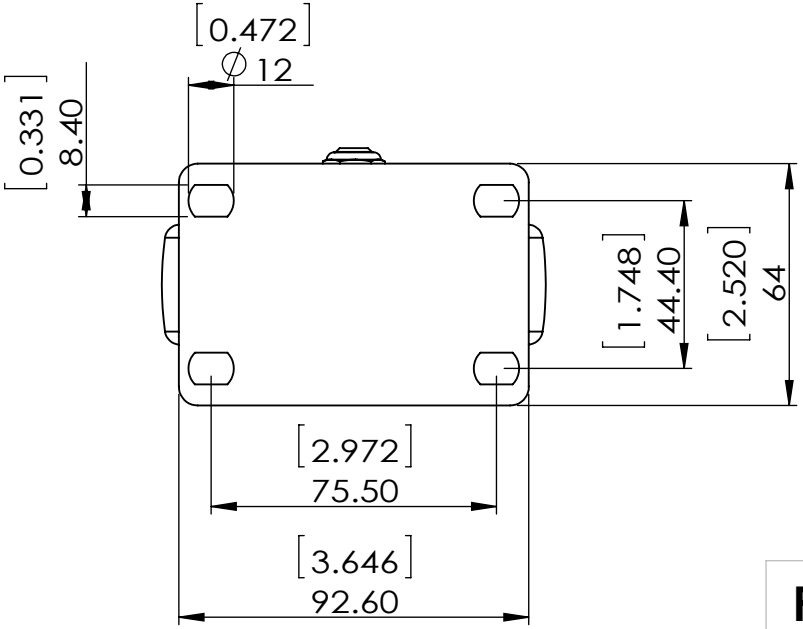

Dimensions in mm [ inch ]

<b>P&amp;H Casters</b>		Scale <b>1:2</b>	Volume ( mm <sup>3</sup> )	Drawn By: Hua	Date 2019/4/30
Description CASTER				Reviewed Andy	 <small>FIRST ANGLE PROJECTION</small>
Part Number Z27P144CTKI REV A	Revision	Sheet <b>01</b>	Date 2019/4/30		