

REV NO.	Revision Note	Signature	Date	Checked	Date

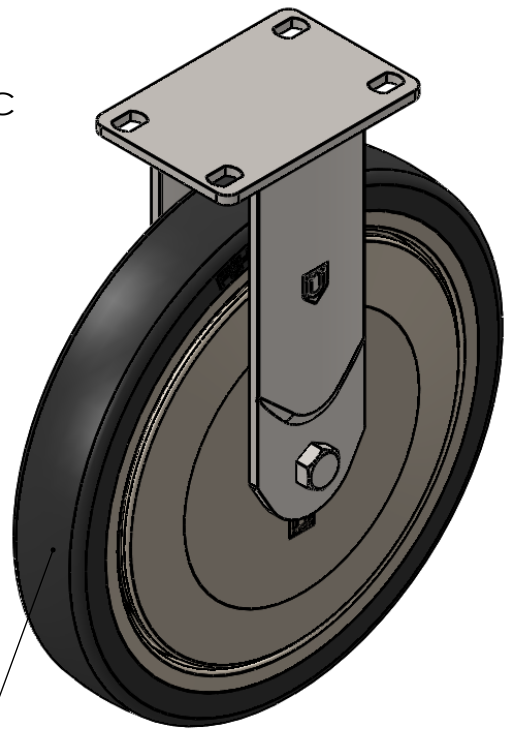

Durometer: Shore D 46 (+/-5)

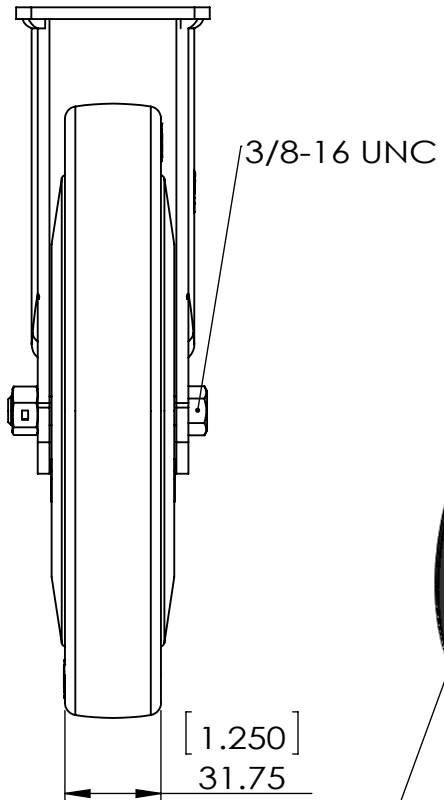
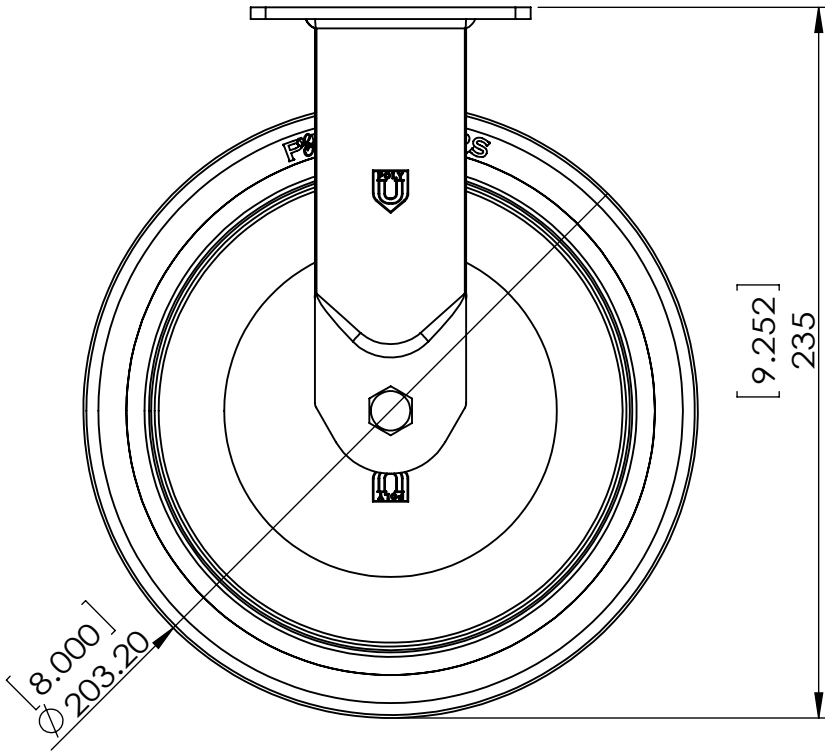
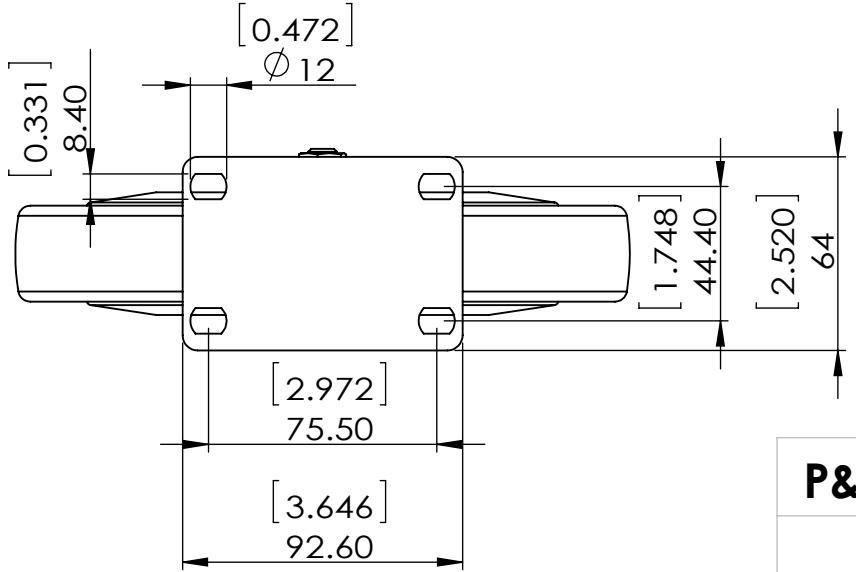

Dimensions in mm [inch]

P&H Casters		Scale	1:2.5	Volume (mm ^ 3)	Drawn By:	Date
Description		CASTER		Reviewed	Hua	2019/4/10
Part Number	Revision	Sheet	01	Date	Andy	 FIRST ANGLE PROJECTION
Z27P184CTKH	REV A			2019/4/10		