

REV NO.	Revision Note	Signature	Date	Checked	Date

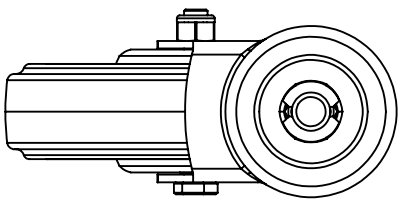
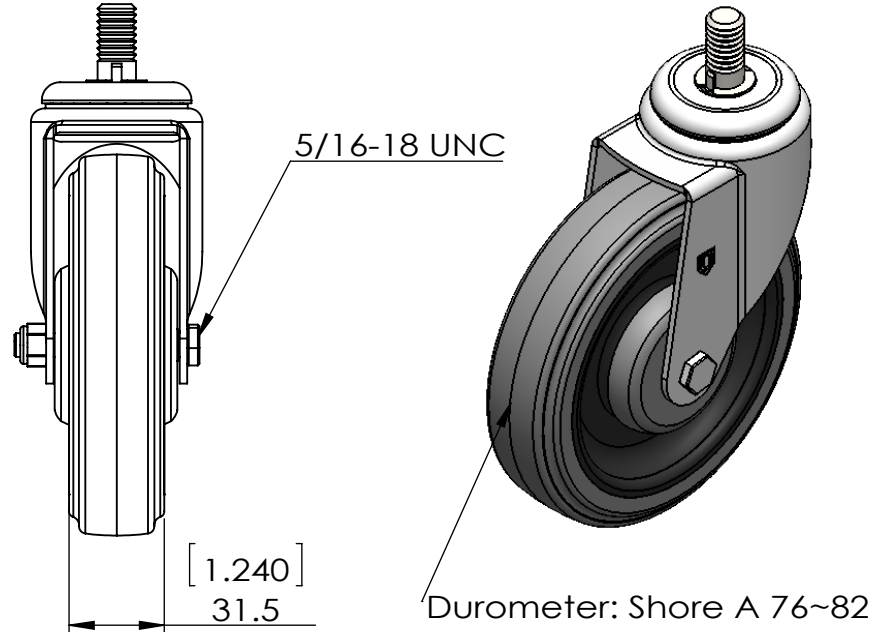
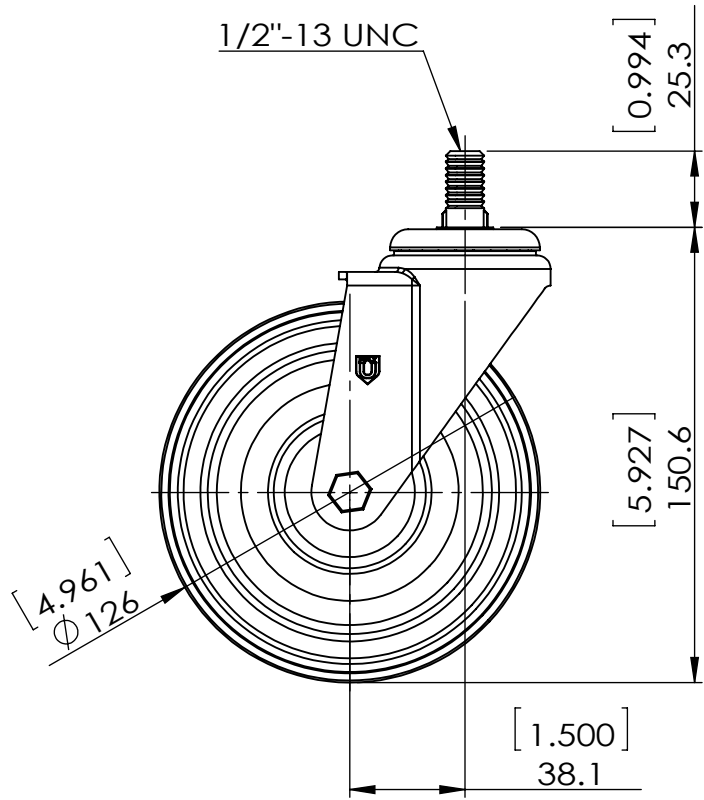

Dimensions in mm [inch]

Tolerance unless otherwise specified	
Over- up to (mm)	Tolerance (mm)
0-10	±0.1
10-30	±0.2
30-120	±0.3
120-400	±0.5

P&H Casters		Scale 1:2.5	Volume (mm ³)	Drawn By: Hua	Date 2019/9/11
Description CASTER				Reviewed Andy	 FIRST ANGLE PROJECTION
Part Number Z30C154NEDE	Revision REV A	Sheet 01	Date 2019/9/11		