

REV NO.	Revision Note	Date	Signature	Checked

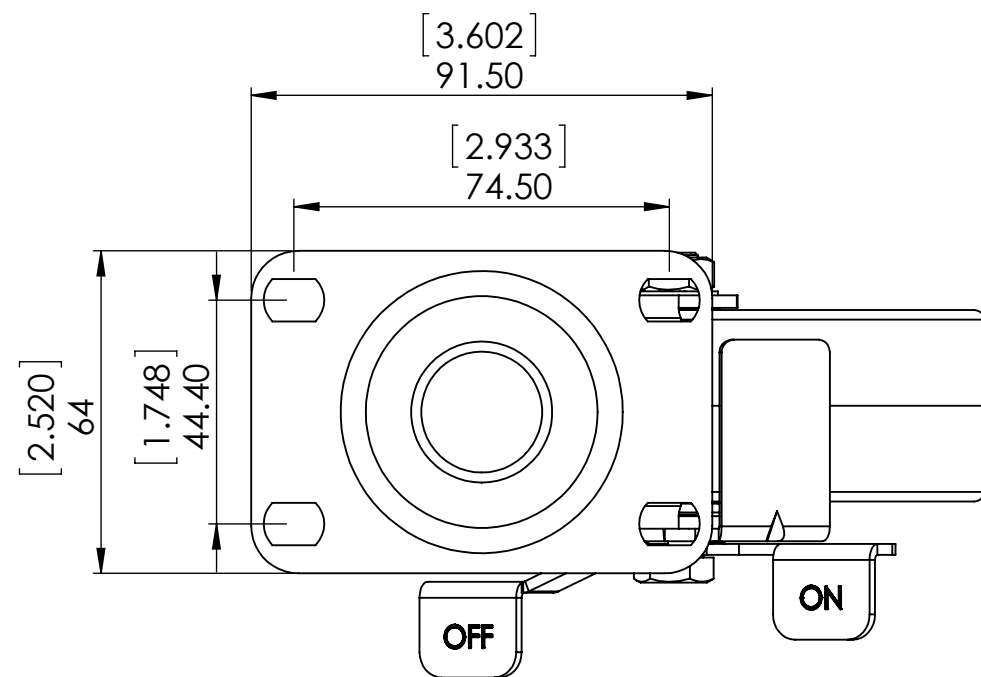
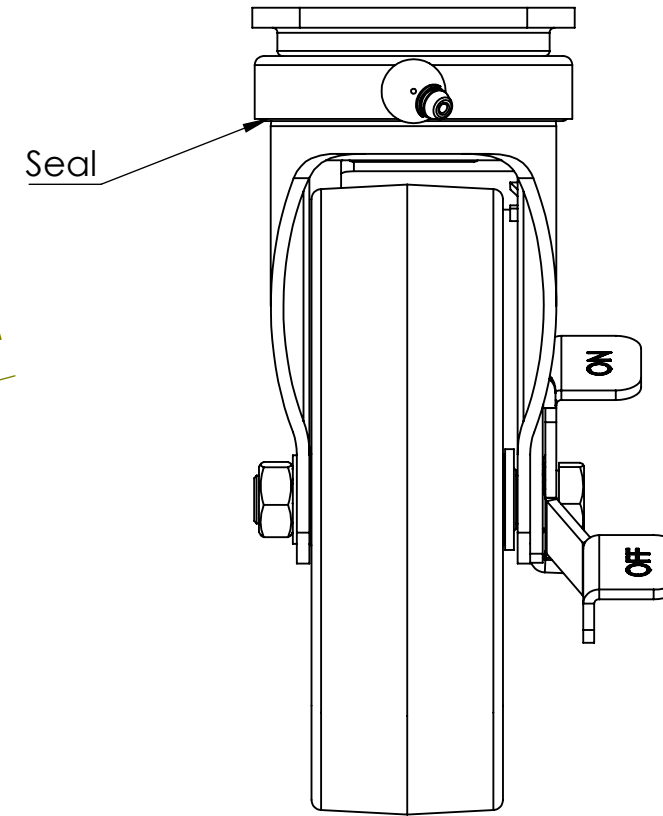
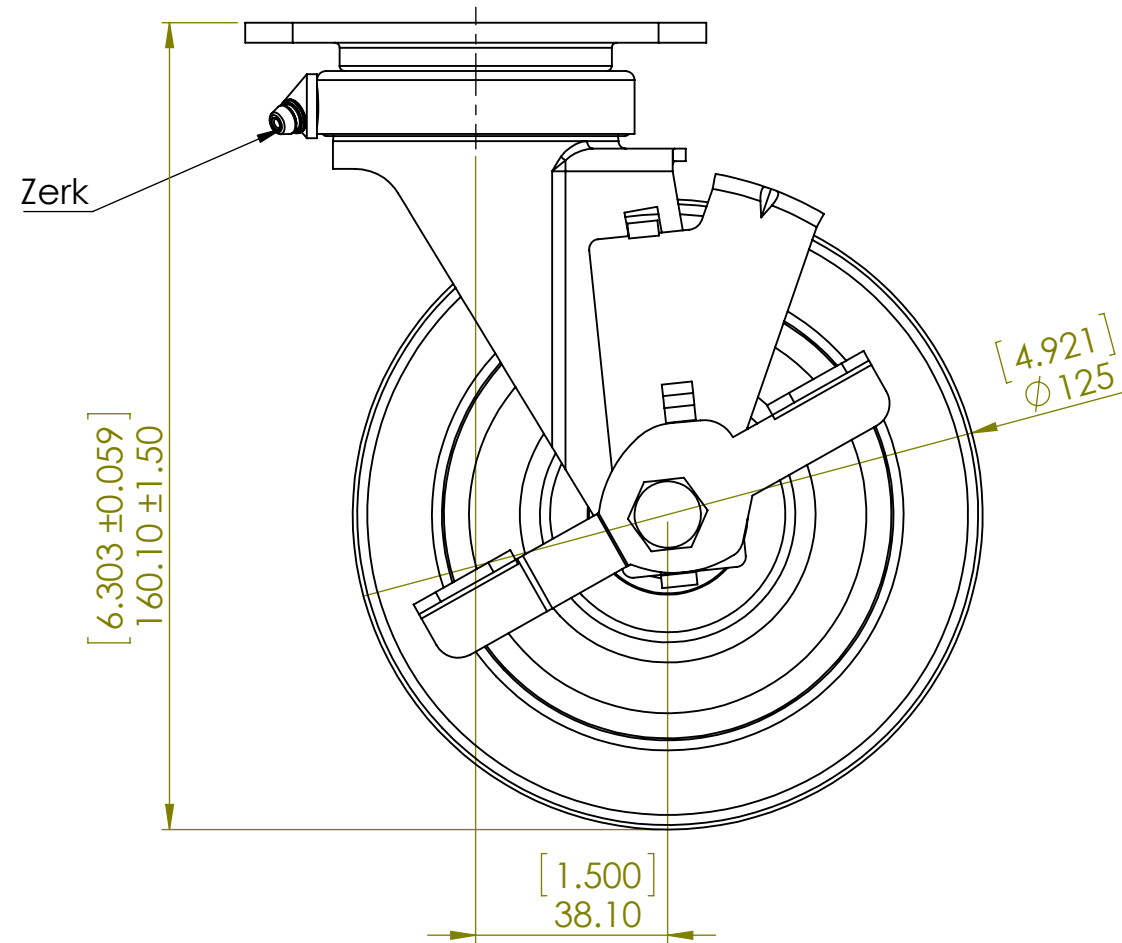
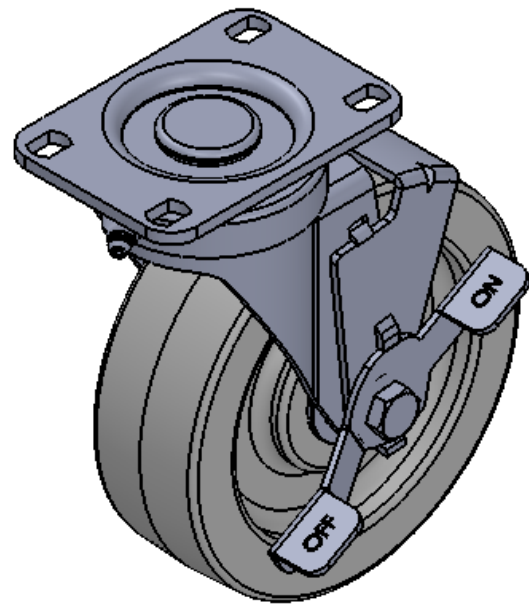

Notes:

- 1- Fork/rig assembly 304 Stainless Steel.
- 2- Wheel 5x1.5, Gray (PMS 424) Retort.
- 3- Bearings: Precision Sealed ball bearing SS 420
- 4- Load capacity 400 lbs.
- 5- Temperature range: -20 to 290 F
- 6- Seal material: Polytetrafluoroethylene

Dimensions in mm [ in ]

<b>P&amp;H Casters</b>	Scale 1:1	Volume (mm <sup>3</sup> )	Drawn By: Jorge	Date 3/3/2016
Description			P&H Approval	
Part Number T26P1530GKJFS	Revision REV A	Sheet 01	Date	