

REV NO.	Revision Note	Signature	Date	Checked	Date

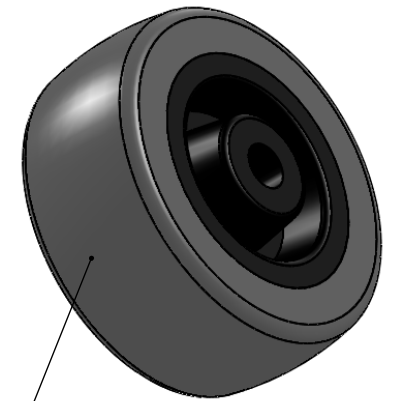
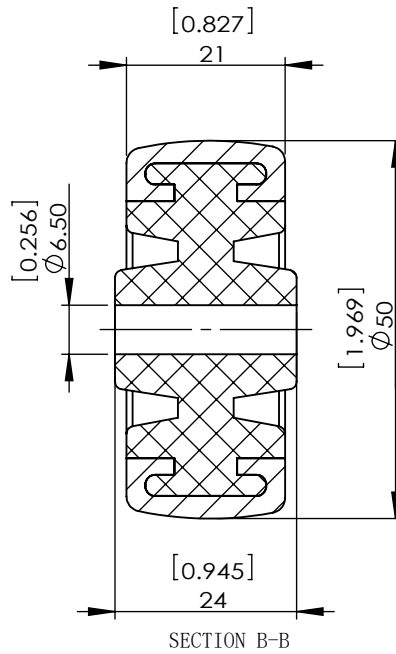
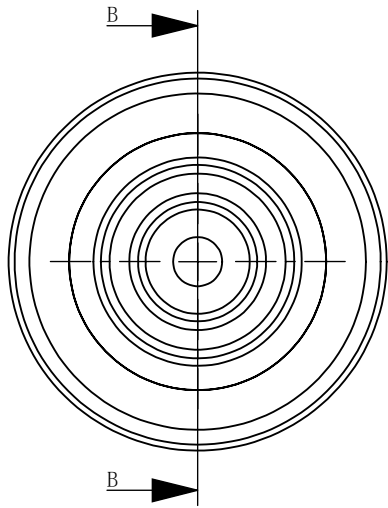

Durometer: Shore A 70 (+/-5)

Dimensions in mm [inch]

P&H Casters		Scale 1:1	Volume (mm ³)	Drawn By: Hua	Date 2019/5/29
Description WHEEL			Reviewed Andy		
Part Number WN1027EA	Revision REV A	Sheet 01	Date 2019/5/29		