

REV NO.	Revision Note	Signature	Date	Checked	Date

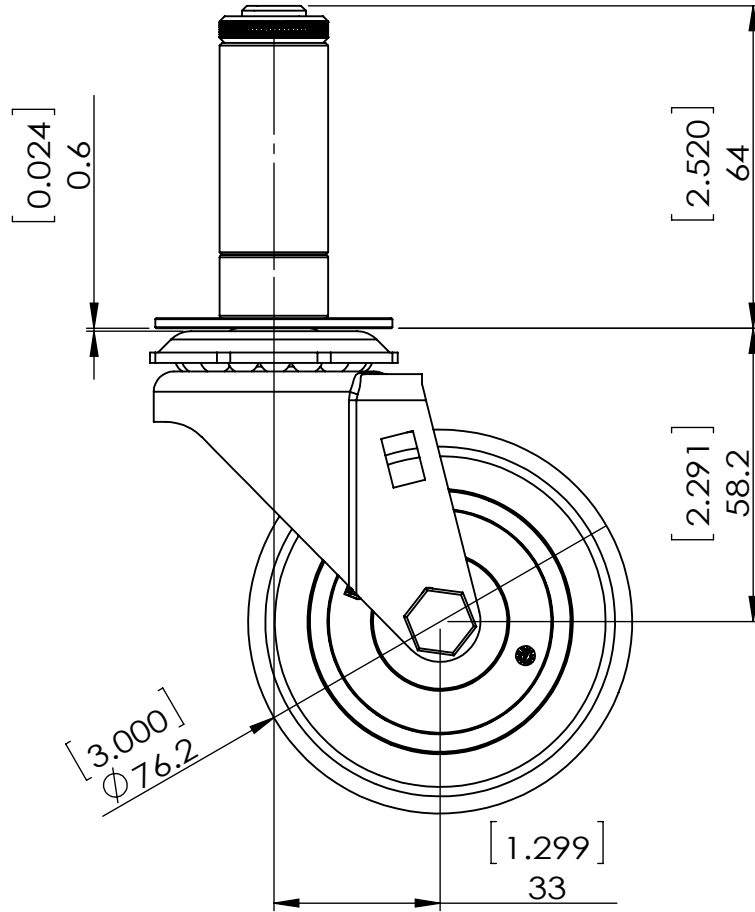

Dimensions in mm [inch]

P&H Casters		Scale	1:1.5	Volume (mm ³)	Drawn By:	Date
Description				CASTER		
Part Number		Revision		Sheet	Date	
Z10X231ABCE		REV A		01	2019/10/12	
					Hua	2019/10/12
					Andy	

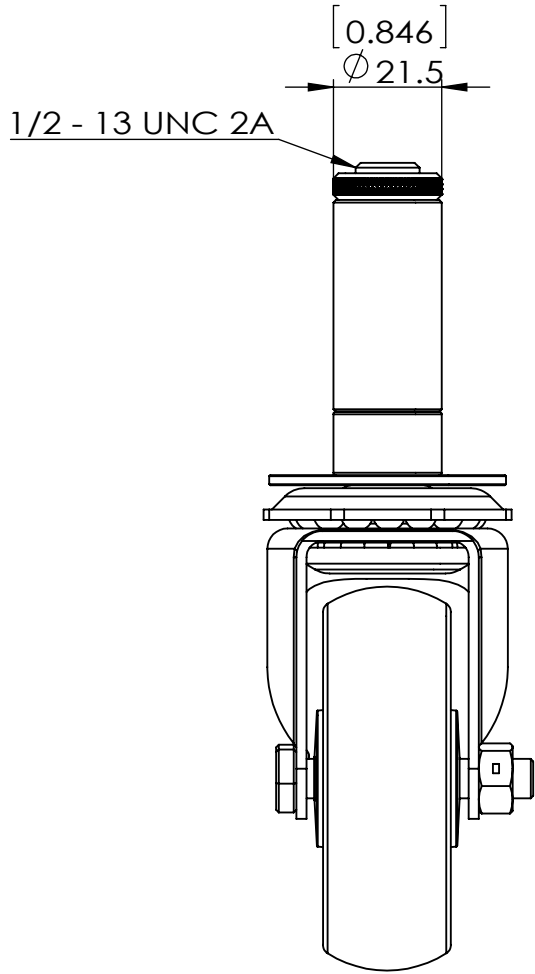