

Zinc-plated steel nut, thread lock with axle

Black phenolic 4x2 wheel, plain bore with POM inserts: WL4042B6

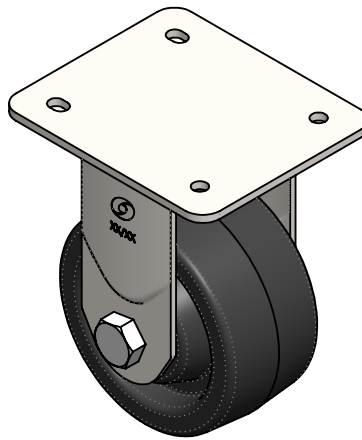
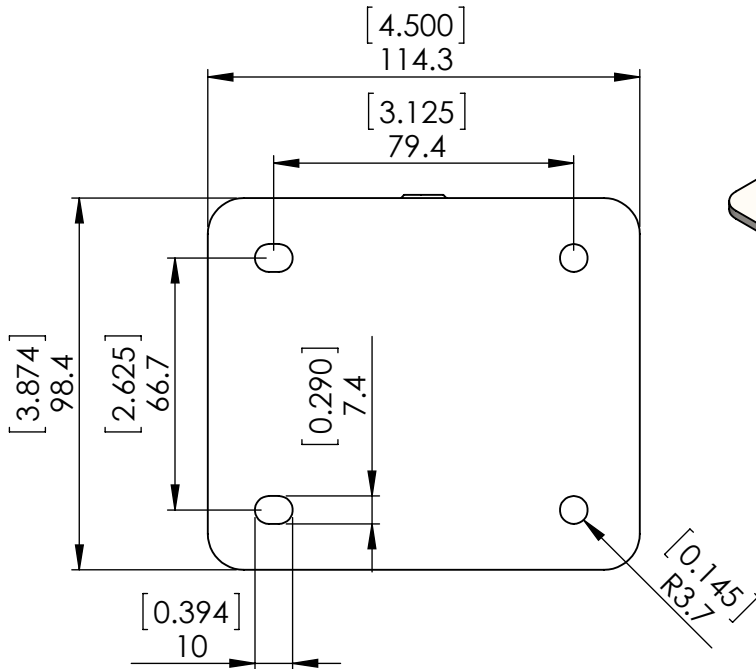
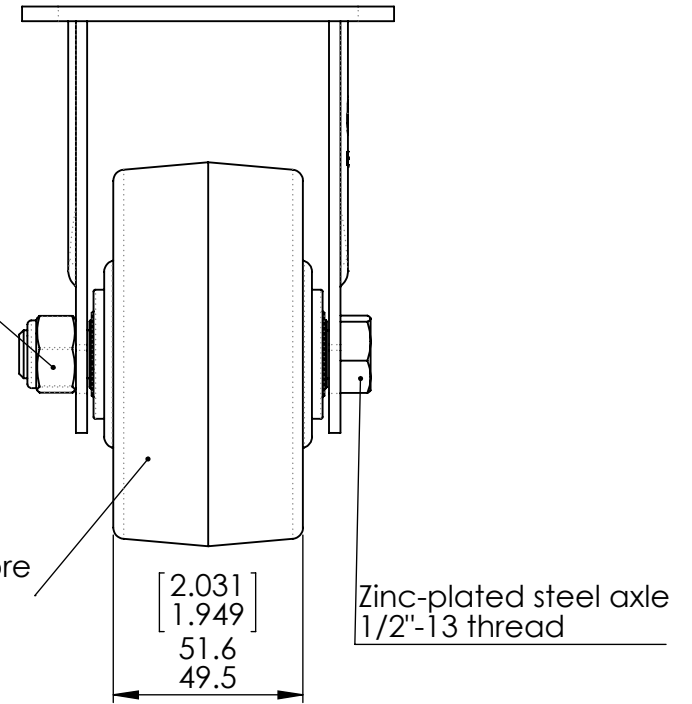

Tolerance unless otherwise specified	
Over- up to (mm)	Tolerance (mm)
0-10	±0.15
10-30	±0.25
30-120	±0.35
120-400	±0.6

Angular deviation +/- 1°

NOTES:

1 - Dimensions in mm [inch]

2 - Caster: Electrodeposited Zinc plating to withstand 48hr salt spray test according to ASTM B117-03. Results evaluated according to ASTM D610-01.

3 - Operating temp: -20F to +180F
Low temperature grease performance established according to ASTM 1478

4 - Load capacity: 400lb
Tested according to ANSI ICWM:2012, Section 6.

P&H Casters	Scale 1:2	Volume (mm ^ 3)	Drawn By: Ronny	Date 9/24/2018
Description			P&H Approval	
Part Number H22P342LB6L REV A	Revision	Sheet 01	Date	