

Durometer: Shore A70 (+/-5)
 Wheel P/N: WK4062G86

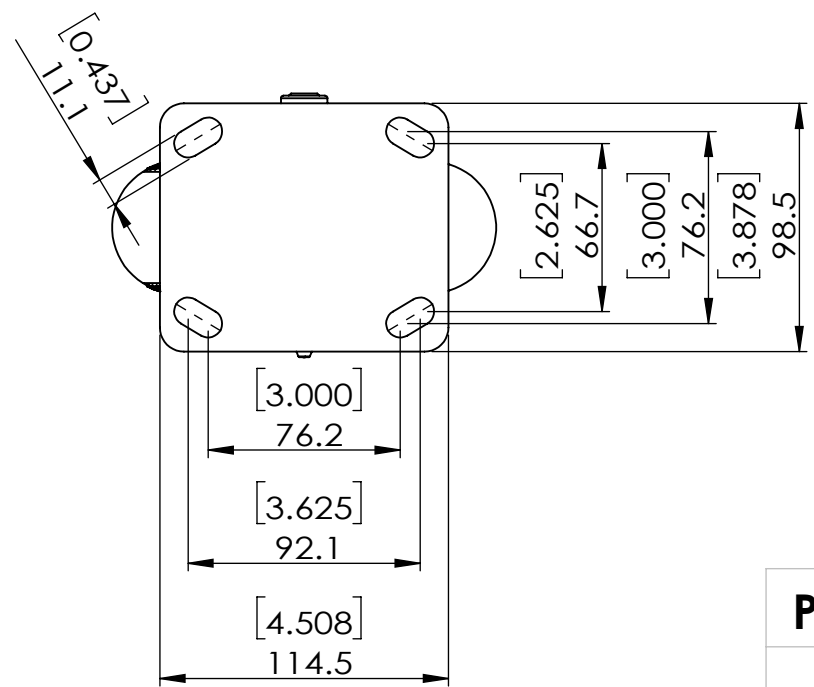
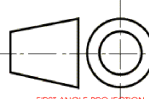

Load capacity: 450 lbs Dimensions in mm [in]

P&H Casters	Scale: 1:3	Weight (lbs): 4.2	Drawn By: Ronny	Date: 2024/06/11
Description: CASTER			Reviewed By: Andy	 <small>FIRST ANGLE PROJECTION</small>
Part Number: N42P362KGNZGL	Revision: REV A	Sheet: 01	Date: 2024/06/11	