

Durometer: Shore A65 (+/-5)
Wheel P/N: WC4062CP

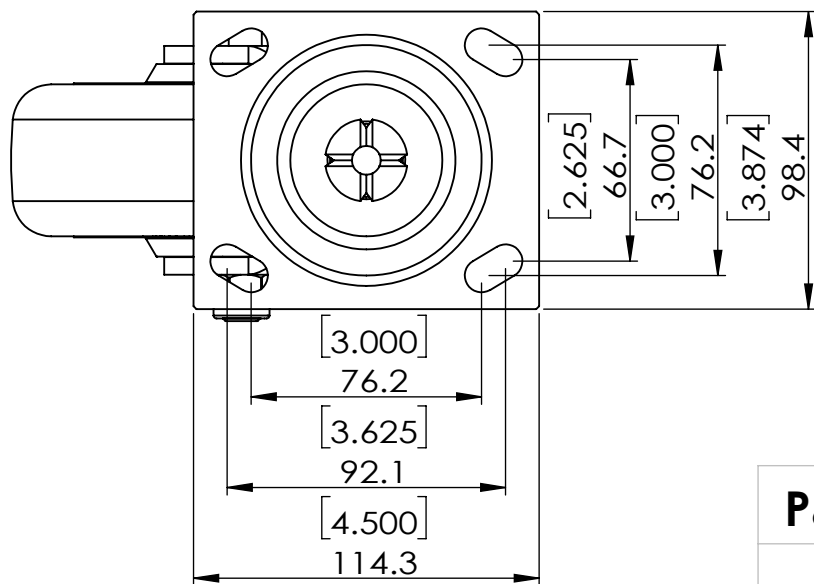
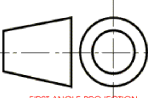

Load capacity: 450 lbs

Dimensions in mm [in]

P&H Casters	Scale: 1:2.5	Weight (lbs): 5.4	Drawn By: Hua	Date: 2024/5/17
Description: CASTER			Reviewed By: Andy	 FIRST ANGLE PROJECTION
Part Number: Z40P362NCPLO	Revision: REV A	Sheet: 01	Date: 2024/5/17	