

Durometer: Shore D90 (+/-5)  
 Wheel P/N: 3-171C-B

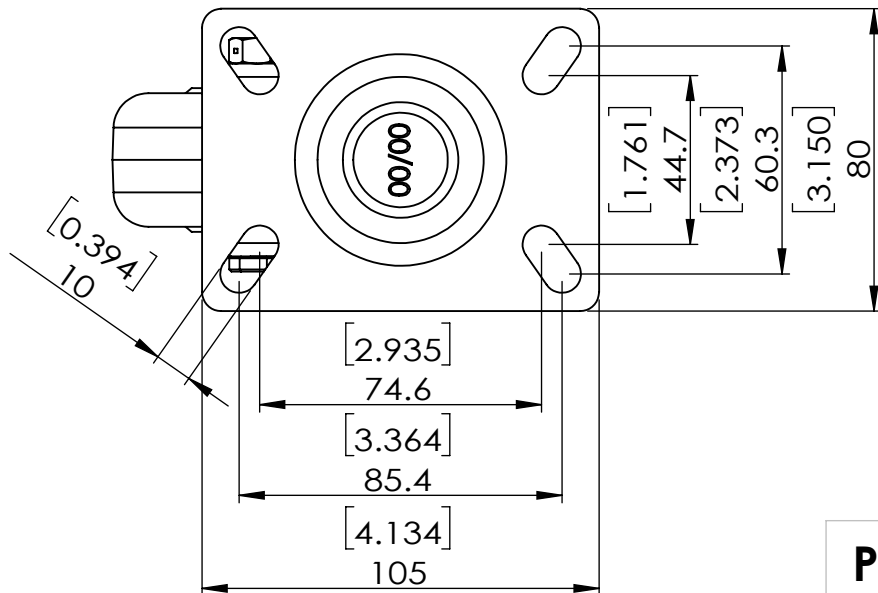

Dimensions in mm [ in ]

<b>P&amp;H Casters</b>	Scale: <b>1:2</b>	Weight ( lbs ): 1.9	Drawn By: Hua	Date: 2024/7/10
Description: WHEEL			Reviewed By: Andy	
Part Number: Z20P230HBCDF	Revision: REV A	Sheet: <b>01</b>	Date: 2024/7/10	