

Durometer: Shore D46 (+/-5)
Wheel P/N: WC3054GD

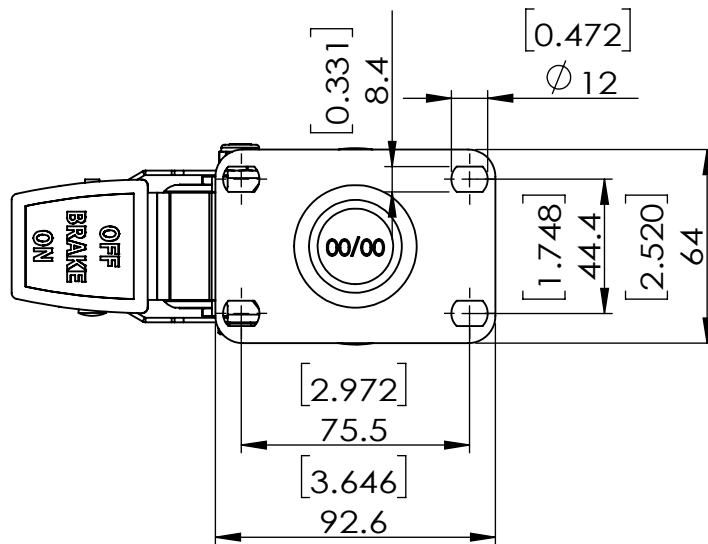

Load capacity: 250 lbs

Dimensions in mm [in]

P&H Casters	Scale: 1:2.5	Weight (lbs): 2.2	Drawn By: Hua	Date: 2024/3/27
Description: CASTER			Reviewed By: Andy	
Part Number: Z20P154CGDEZK	Revision: REV A	Sheet: 01	Date: 2024/3/27	