

Durometer: Shore D90 (+/-5)
 Wheel P/N: 35-171M-B

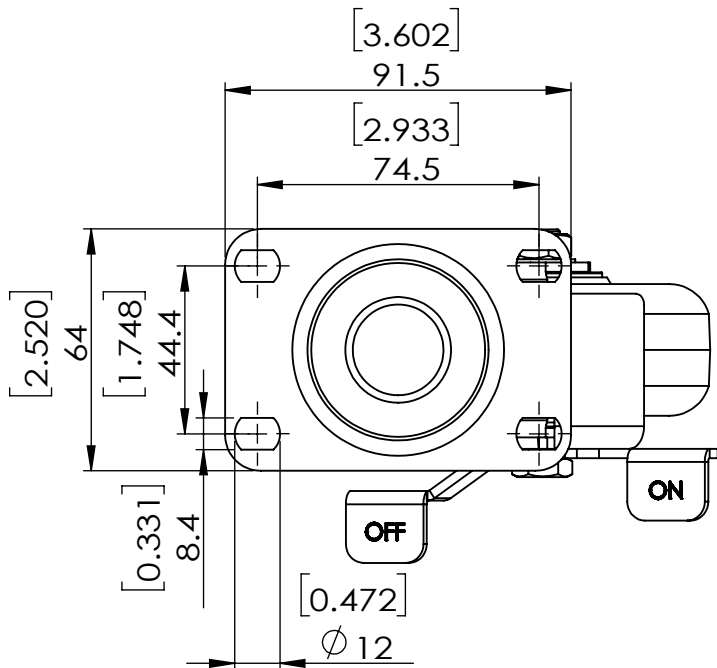

Dimensions in mm [in]

P&H Casters	Scale: 1:2	Weight (lbs): 2.3	Drawn By: Hua	Date: 2024/10/22
Description: CASTER			Reviewed By: Andy	 FIRST ANGLE PROJECTION
Part Number: T26P173HBKJFS	Revision: REV A	Sheet: 01	Date: 2024/10/22	